

Ventilators

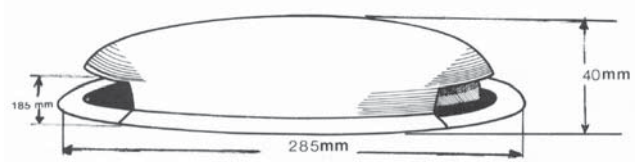

7.33183

Exterior Muller vent. Available in white **ABS** plastic only. To suit up to 130mm diameter aperture.



Solid Top Ventilator

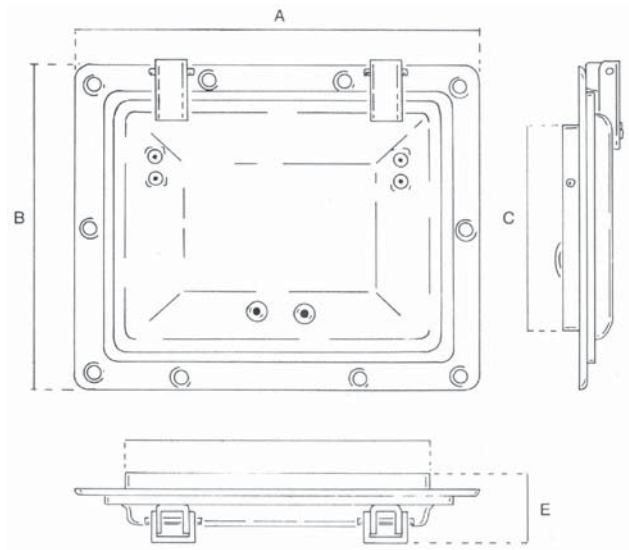

- Lid:** Black jappanned mild steel pressing formed to ensure rigidity and flatness.
- Finger Pull:** 3.5mm diameter, wire formed ring.
- Mechanism:** Unique coil spring action giving positive hold in both open and closed position. There is also considerable protection against 'over-opening'.
- Flange:** One piece aluminium pressure die-casting.
- Weather Seal:** Sponge rubber.

Part No.	A	B	C	D	E	Nom.Size
<u>7.0623/001</u>	265	214	169	220	31	8.5" x 6.5"
<u>7.0623/003</u>	238	147	102	193	31	7.5/8" x 4"
<u>7.0623/002</u>	337	261	203	279	31	11" x 8"

