

Tipper Parts

Corner Post Catch

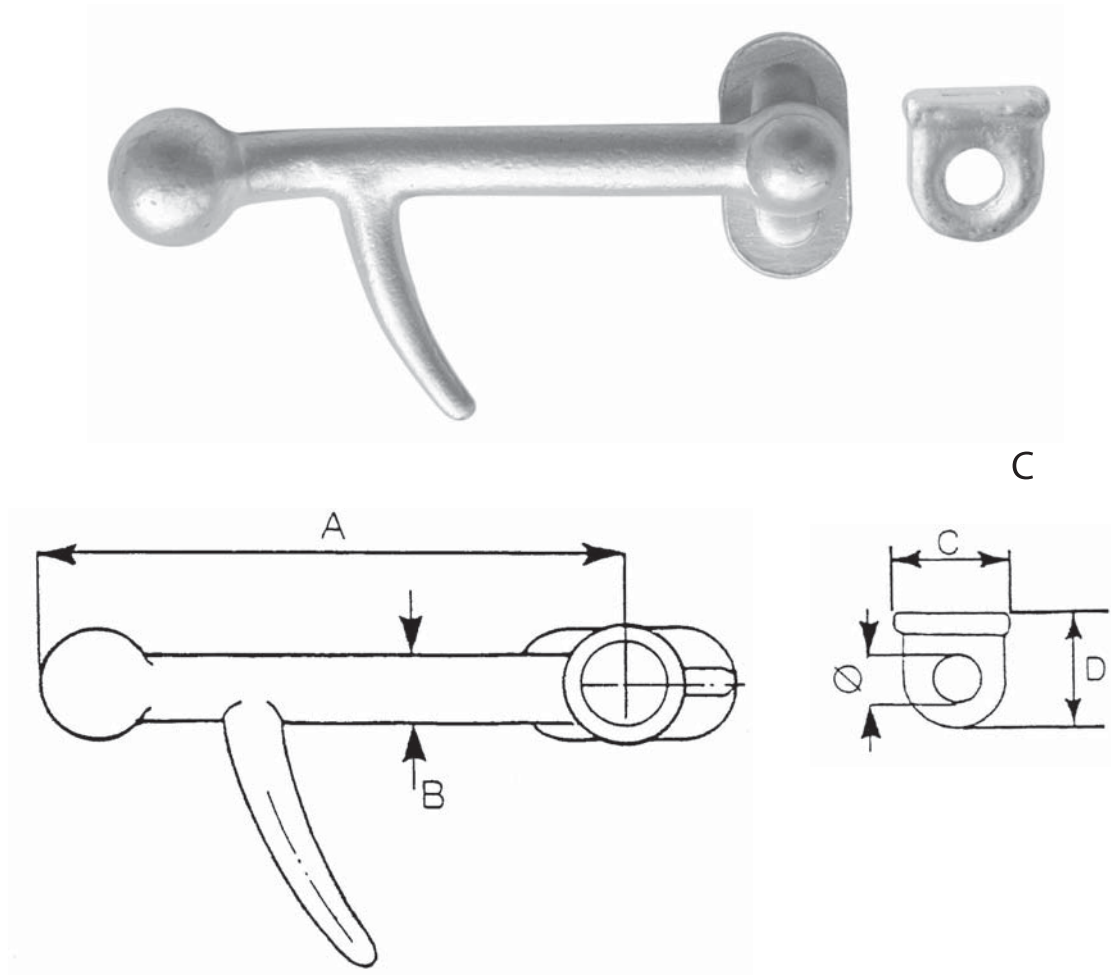

Corner Latch				
Part No.		A	B	kg
8.20-001LH	Very light	105	11	0,180
8.20-001RH	Very Light	105	11	0,180

8.20-003LH	Light duty	130	13	0,240
8.20-003RH	Light duty	130	13	0,240

8.20-005LH	Medium duty	150	15	0,380
8.20-005RH	Medium duty	150	15	0,380

8.20-007LH	Heavy duty	150	17	0,850
8.20-007RH	Heavy duty	150	17	0,850

Eyebolt				
Part No.	O	C	D	kg
8.20-002	10	27	26	0,030
8.20-004	12	31	30	0,040
8.20-006	15	35	33	0,060
8.20-008	17	42	42	0,090

