

Paddle Latches – Large

- Metal slide.
- Pull paddle to open.
- Locking and non-locking versions.
- Latch is flush with outer panel.
- Single-hole installation.

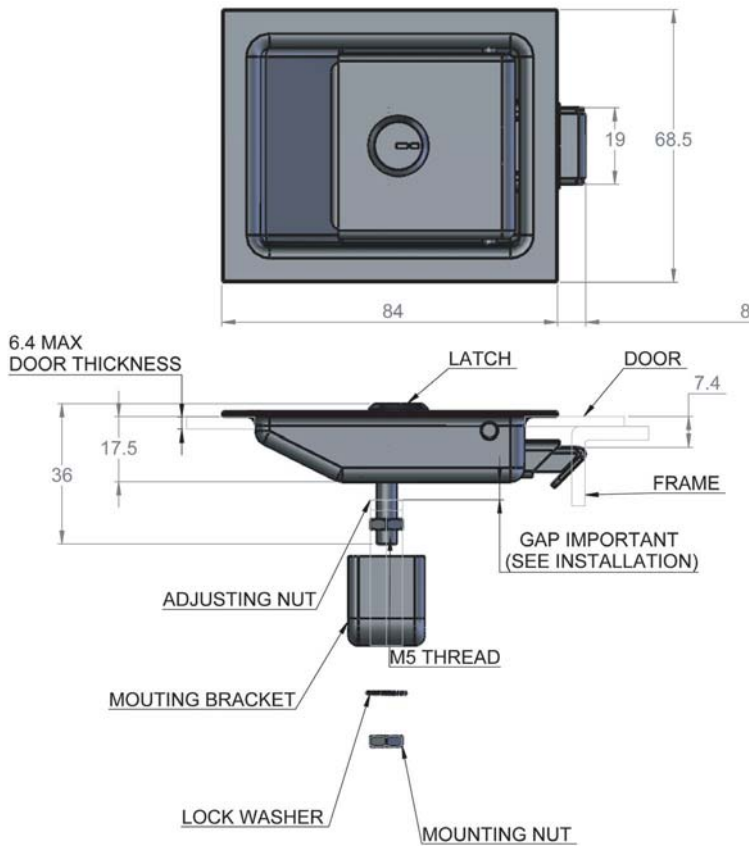

Finish	20 Series Part Numbers without lock	20 Series Part Numbers with Lock*
Stainless Steel		
Brushed	4.64-21-10	4.64-22-10
Steel		
Zinc	4.64-21-13	4.64-22-13
Powder Coat		
Black	4.64-21-11	4.64-22-11

* Locks are keyed alike. Different key codes are available.

Material and Finish:

Cup and paddle: 1010 Stainless Steel, zinc plated plus bright chromate dip or powder coated (black or stain silver) or 304 Stainless Steel passivated and brushed finish. **Guide and slide:** 1010 Steel, zinc plated plus bright chromate dip or 304 stainless Steel, passivated. **Spring:** 302 Stainless steel, passivated. **Lockwasher:** Spring steel, zinc alloy plate, bright chromate plus sealer or 304 Stainless Steel. **Stud:** 10B21 Steel, zinc alloy plate, bright chromate plus sealer or 302 Stainless Steel, passivated. **Pin:** 302 Stainless Steel, passivated. **Nut:** Steel, zinc plate, chromate plus sealer or stainless steel, passivated..

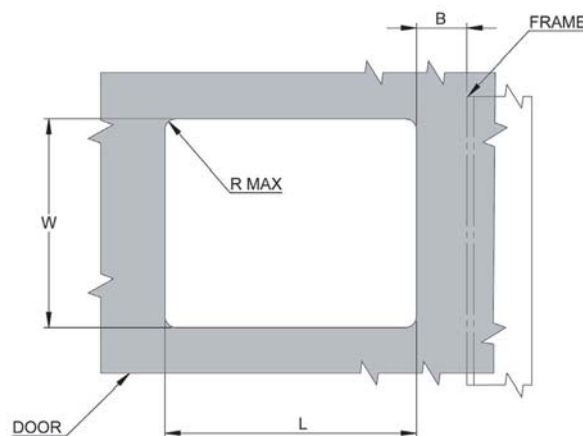

HEAD OFFICE T: +61 02 8887 1200 F: +61 02 8887 1249 E: export@uesint.com	NEW SOUTH WALES T: +61 02 8787 6500 F: +61 02 8787 6599 E: uesnw@uesint.com	QUEENSLAND T: +61 07 3623 5800 F: +61 07 3865 5605 E: uesqld@uesint.com	VICTORIA T: +61 03 8787 3100 F: +61 03 8787 3101 E: uesvic@uesint.com	SOUTH AUSTRALIA T: +61 08 8340 1599 F: +61 08 8340 4423 E: uessa@uesint.com	WESTERN AUSTRALIA T: +61 08 9249 2211 F: +61 08 9249 2022 E: ueswa@uesint.com	NORTHERN TERRITORY T: +61 08 8946 4500 F: +61 08 8946 4555 E: uesnt@uesint.com	NEW ZEALAND T: +64 09 633 4019 F: +64 09 633 0249 E: uesnz@uesint.com		

