

Lift And Turn Latches

- Use in NEMA 4 and IP-66 applications with optional sealing gasket.
- Hand-tool, or key-actuation options.
- Locking and non-locking versions use same panel preparation.

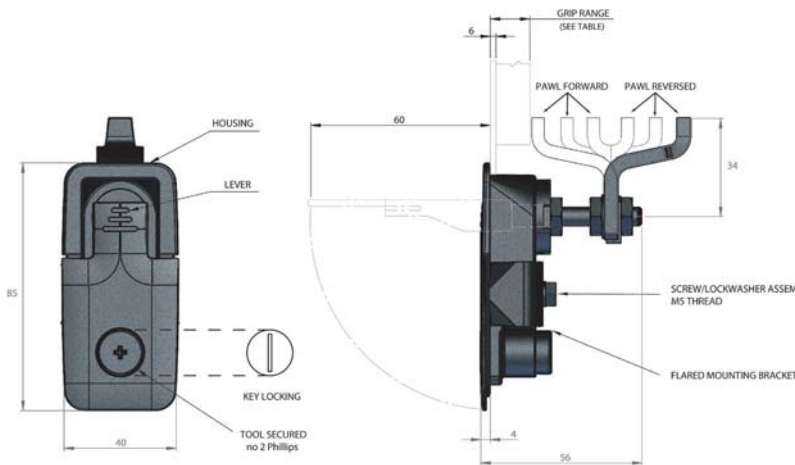

Material and Finish:

Housing and Lever: Die-cast zinc (see table). **Shaft:** 12L14 Steel, zinc plate, chromate plus sealer or with black organic coating. **Shaft O-ring:** Synthetic rubber, black. **Cam:** 1010 Steel, zinc plate, chromate plus sealer or with black organic coating. **Pin:** 303 Stainless Steel, passivated. **Washer:** 1010 Steel, zinc plated bright or black oxide. **Springs:** 302 Stainless Steel, passivated. **Bearing Washer, Pawl, Pawl Retaining Clip and Bracket:** 1010 Steel, Zinc plate, chromate plus sealer. **Lockwasher:** Spring Steel, zinc plate, chromate plus sealer. **Nuts and Screw/Lockwasher Assembly:** Low carbon steel, zinc plate, chromate plus sealer. **Keys:** Brass, nickel plated.

For Dust and Moisture Sealed Models
Cup Sealing Gasket: Synthetic rubber, natural.

For Key-locking and Tool-Secured Models - Lock Plug: die-cast zinc, chrome plated or black power coat.

Product Strength Guidelines: Maximum working load: 440N

Sealing Note: NEMA 4/IP-66 sealing is achieved by using the environmental CUP SEALING GASKET and sealing the mounting screw threads with a suitable material such as an anaerobic sealant.

Installation

1. Prepare a rectangular opening as shown.
4. Pawl should be adjusted to GRIP measurement with the door open and the lever in the LATCHED position. Use two 13mm spanners to tighten nuts.

Grip Range		Part Numbers (Layer packed - 20 piece minimum. Sold in multiples of 20)*			
Pawl Forward	Pawl Reversed	Style	TEXTURED CHROME	BLACK POWDER	POLISHED CHROME
MIN -MAX	MIN -MAX				
6-16	56-66	BASIC	4.62-40-101-3	4.62-40-151-3	4.62-40-111-3
16-26	46-56		4.62-40-201-3	4.62-40-251-3	4.62-40-211-3
26-36	36-46		4.62-40-301-3	4.62-40-351-3	4.62-40-311-3
6-16	56-66	KEY-LOCKING	4.62-42-101-3	4.62-42-151-3	4.62-42-111-3
16-26	46-56		4.62-42-201-3	4.62-42-251-3	4.62-42-211-3
26-36	36-46		4.62-42-301-3	4.62-42-351-3	4.62-42-311-3
6-16	56-66	TOOL-LOCKING	4.62-43-101-3	4.62-43-151-3	4.62-43-111-3
16-26	46-56		4.62-43-201-3	4.62-43-251-3	4.62-43-211-3
26-36	36-46		4.62-43-301-3	4.62-43-351-3	4.62-43-311-3

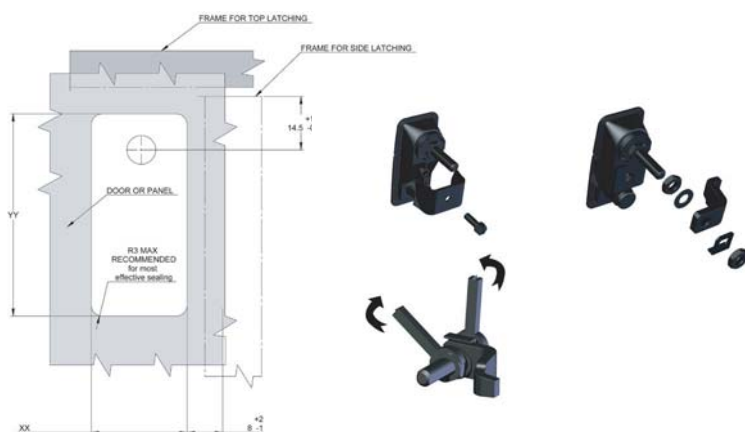

<p>HEAD OFFICE T: +61 02 8887 1200 F: +61 02 8887 1249 E: export@uesint.com</p>	<p>NEW SOUTH WALES T: +61 02 8787 6500 F: +61 02 8787 6599 E: uesnsw@uesint.com</p>	<p>QUEENSLAND T: +61 07 3623 5800 F: +61 07 3865 5605 E: uesqld@uesint.com</p>	<p>VICTORIA T: +61 03 8787 3100 F: +61 03 8787 3101 E: uesvic@uesint.com</p>	<p>SOUTH AUSTRALIA T: +61 08 8340 1599 F: +61 08 8340 4423 E: uessa@uesint.com</p>	<p>WESTERN AUSTRALIA T: +61 08 9249 2211 F: +61 08 9249 2022 E: ueswa@uesint.com</p>	<p>NORTHERN TERRITORY T: +61 08 8946 4500 F: +61 08 8946 4555 E: uesnt@uesint.com</p>	<p>NEW ZEALAND T: +64 09 633 4019 F: +64 09 633 0249 E: uesnz@uesint.com</p>
---	---	--	--	--	--	---	--