

Aluminium / Rubber Hinges

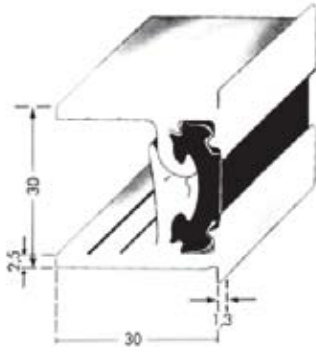

Closed

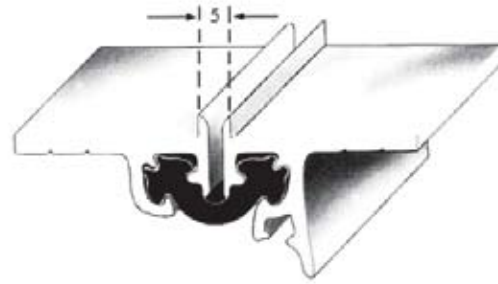

Open 180°

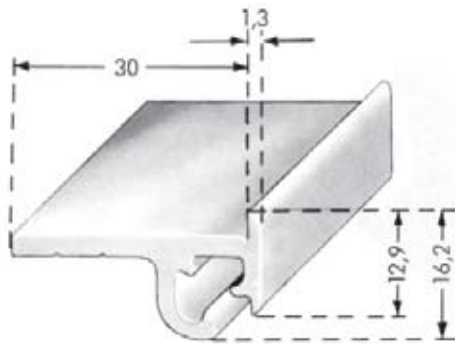

2.372-0235

Hinge upper profile.

Material: AlMgSi 0.5 F22 anodized E6/EV1.

Weight: 400g/m S.U. 10m.

Length: 5m.



2.405-0003

Hinge section.

Material: EPDM 70 Sh.

Weight: 160g/m S.U. 50m.

Roll Size: 50m.

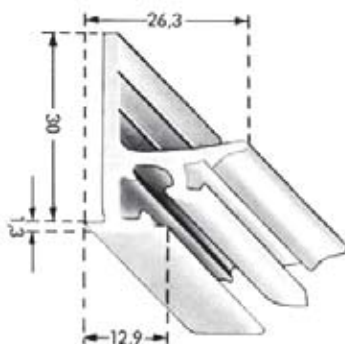

2.372-0236

Hinge lower profile.

Material: AlMgSi 0.5 F22 anodized E6/EV1.

Weight: 500g/m S.U. 10m.

Length: 5m.



HEAD OFFICE
T: +61 02 8887 1200
F: +61 02 8887 1249
E: export@uesint.com

NEW SOUTH WALES
T: +61 02 8787 6500
F: +61 02 8787 6599
E: uesnsw@uesint.com

QUEENSLAND
T: +61 07 3623 5800
F: +61 07 3865 5605
E: uesqld@uesint.com

VICTORIA
T: +61 03 8787 3100
F: +61 03 8787 3101
E: uesvic@uesint.com

SOUTH AUSTRALIA
T: +61 08 8340 1599
F: +61 08 8340 4423
E: uessa@uesint.com

WESTERN AUSTRALIA
T: +61 08 9249 2211
F: +61 08 9249 2022
E: ueswa@uesint.com

NORTHERN TERRITORY
T: +61 08 8946 4500
F: +61 08 8946 4555
E: uesnt@uesint.com

NEW ZEALAND
T: +64 09 633 4019
F: +64 09 633 0249
E: uesnz@uesint.com